

THREE FIVE MATERIALS

T: 212-213-8290

F: 212-213-6906

InGaAs / InP PIN PD Chip ---TCP0988

1. Scope

- Apply to large area photo-diode chip.
- Type : TCP0988

2. Structure

- InGaAs / InP PIN Chip.
- P Electrode (anode) : Gold.
- N Electrode (cathode) : Gold.

3. Size

- Chip size : $2190 \times 2265 \pm 25\mu\text{m}$
- Thickness : $300 \pm 25\mu\text{m}$
- Active area : $2000 \times 2000\mu\text{m}$
- Pattern drawing : per fig. 1

4. Electro-Optical Characteristics

($T_a = +25^\circ\text{C}$)

Parameter	Symbol	Test Condition	Min.	Typ.	Max.	Unit
Responsivity	R	$V_r=5V, \lambda=1300\text{nm}$	0.90	0.95		A/W
Responsivity	R	$V_r=5V, \lambda=1550\text{nm}$	0.95	1		A/W
Dark Current	I_d	$V_r=5V$		0.8	20	nA
Capacitance	C	$V=5V, 1\text{MHz}$		250	300	pF
Forward Voltage	V_F	$I=3\text{mA}$			0.8	V
Breakdown Voltage	V_B	$1\mu\text{m}$	20			V
Shunt Resistance	R_s	$V=10\text{mV}$	40			$\text{M}\Omega$
Operating Temperature	T_{op}		-40		100	$^\circ\text{C}$
Storage Temperature	T_{st}		-40		125	$^\circ\text{C}$

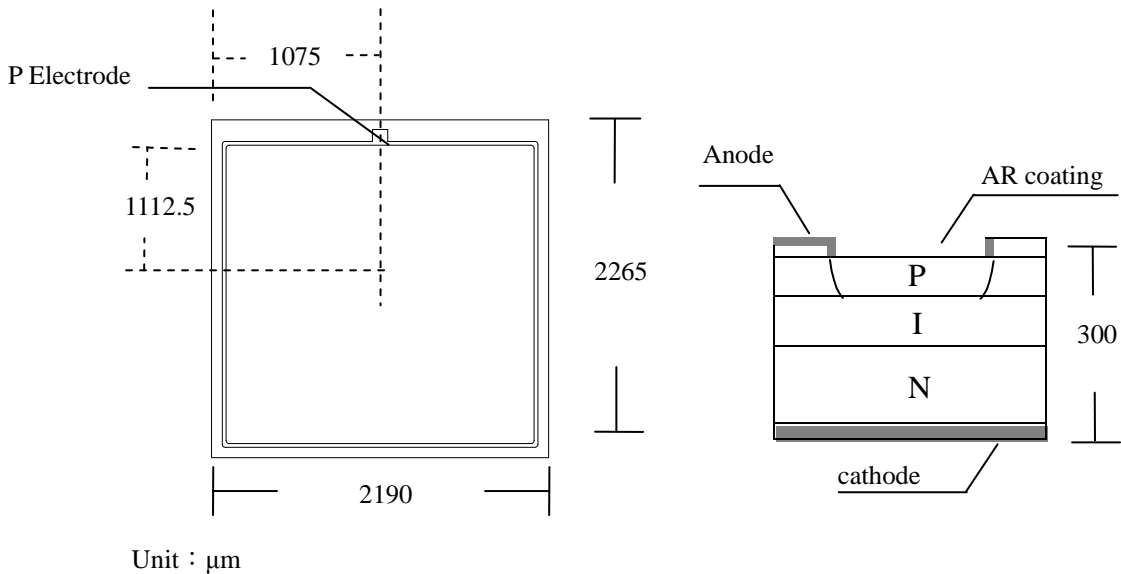

fig. 1